

Simplified H Bridge using 2 Timers

Example: Control a standard brushed DC motor

1. SIMPLIFIED "H" BRIDGE

A "H" Bridge is often drawn with 4 Single Pole Single Throw (SPST) switches (such as relays), or 4 transistors (or similar) controlling a device such as a standard brushed DC motor. This arrangement allows for maximum flexibility (especially when using transistors or similar) while requiring careful control so as not to cause short circuits.

If this flexibility is not required, then it is possible to create a 'simplified' H Bridge using 2 Single Pole **Double** Throw (SPDT) relays as shown in the diagram below. The Logic Table outlines the 4 possible states. Note that none cause a short circuit.

Since each DualTimer controls a SPDT relay, this means that it is possible to control the direction and time a standard DC motor operates using 2 DualTimers. (Naturally the motor's power, current etc must not exceed the specification of the DualTimers' relays.)

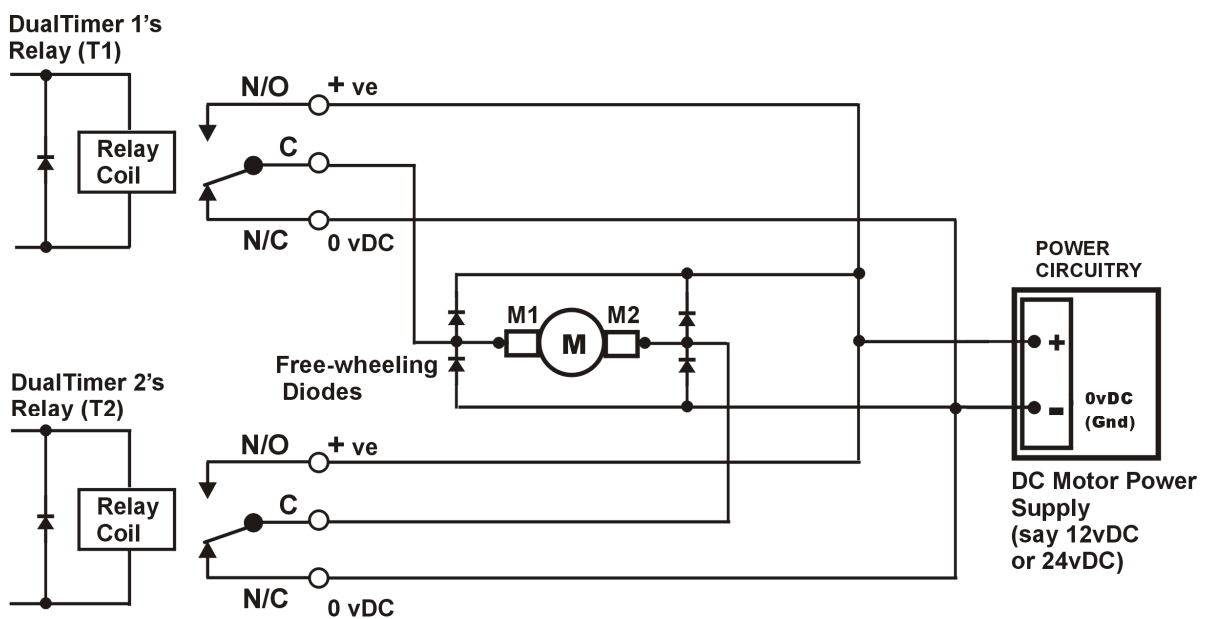

LOGIC TABLE

Relays		Motor		
T1	T2	M1	M2	Operation
OFF	OFF	0v	0v	No Power. Braking*
ON	OFF	+ve	0v	Powered: Clockwise**
ON	ON	+ve	+ve	No Power. Braking*
OFF	ON	0v	+ve	Powered: Anti-clockwise**

* Braking, because both sides of the motor are connected to the same voltage. Remains stationary if already stationary.
 ** Clockwise and Anti-clockwise: For the purposes of this example.

If Pulse Width Modulation (PWM) is required, then separate circuitry is needed. This circuitry would PWM the current going to the motor from either the +ve or 0v terminals located on the DC Motor Power Supply.

NOTE: Refer to disclaimer at the bottom of page 2

2. DUALTIMERS' SETUP AS SIMPLIFIED "H" BRIDGE—NO INTERLOCKS

The below circuit shows how to setup 2 DualTimers as a simplified H Bridge to control a standard DC motor.

- ❑ The red "power" circuitry is the same as that on the previous page and shows the connections between the DualTimers' relays, the motor, and the Motor Power Supply.
- ❑ The black "digital" circuitry shows one way of wiring up the DualTimers.
- ❑ In this example the DualTimers are set up in Time-Out Mode, with -ve (or 0vDC) trigger.
 - ⇒ This means that T1 and T2 are monitoring their respective TRG terminals for a connection to 0vDC. When this happens the Timer activates (or turns On) its relay for the time it had been set to (For T1, this is TIME-1; for T2 this is TIME-2). When S1 is pushed, T1's TRG terminal is connected to 0vDC. When S2 is pushed, T2's TRG terminal is connected to 0vDC.
 - ⇒ The -ve trigger (or 0v DC) set-up often works well with an open collector rather than the momentary switch connected to 0v DC.
 - ⇒ Naturally, it is possible to set up DualTimers with +ve trigger (or any of their other trigger types). This would require variations to the circuitry leading to the TRG terminal(s).

2.1 System Operation

- ❑ When S1 is pushed, T1's relay is activated and if T2's relay is not already activated then the motor is powered for time TIME-1 to enable it to turn (say for the purposes of this example) *clockwise*.
- ❑ When S2 is pushed, T2's relay is activated and if T1's relay is not already activated then the motor is powered for time TIME-2 enabling it to turn *anti-clockwise*.
- ❑ If either S1 or S2 is pressed while the other Timer's relay is activated, then the motor will decelerate (and perhaps stop) for the overlap time (ie while both Timers' relays are activated) and then go in the direction controlled by the Timer whose relay remains activated after the other Timer's relay has deactivated.
 - ⇒ It is possible to develop interlocks using an additional 2 relays which will stop the second Timer being triggered if the other's relay is activated. This is shown on the next page under the heading "DualTimers' Setup as Simplified "H" bridge - Interlock".

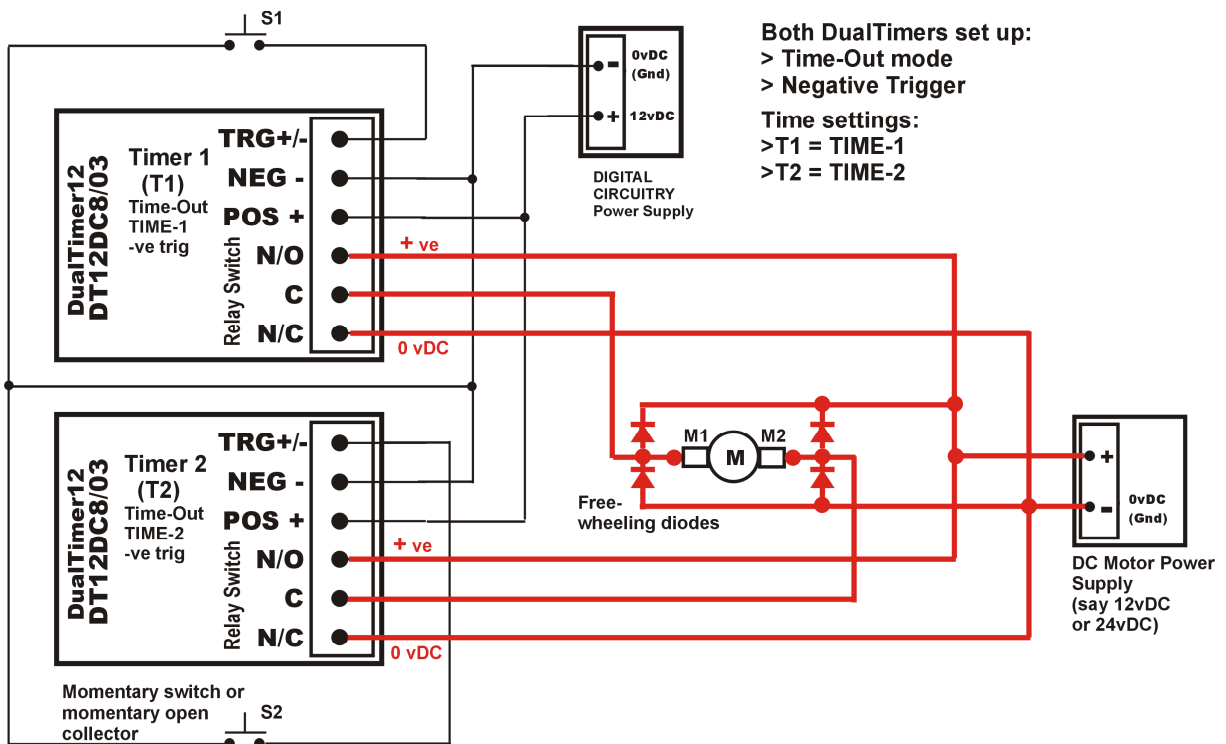

3. DUALTIMERS' SETUP AS SIMPLIFIED "H" BRIDGE—INTERLOCK

The below circuit is a development of that on the previous page with the addition of 2 relays to interlock out the simultaneous activation of both DualTimers' relays.

- ❑ Relay 1's coil is wired up so that it is activated when Timer 1's relay is activated.
- ❑ Relay 1's switch is wired up to supply 0v DC to S2 only when its relay is NOT activated, so Timer 2 can not be triggered while the relay in Timer 1 is activated.
- ⇒ Relay 1 is used to interlock out Timer 2 from being triggered when Timer 1's relay is activated.
- ❑ Similar circuitry can be found around Relay 2 which is used to interlock out Timer 1 from triggering when Timer 2's relay is activated

3.1 System Operation

- ❑ When S1 is pushed, T1's relay is activated causing the motor to be powered for time TIME-1 to enable it to turn (say for the purposes of this example) *clockwise*.
- ❑ When S2 is pushed, T2's relay is activated causing the motor to be powered for time TIME-2 enabling it to turn *anti-clockwise*.
- ❑ If S1 is pushed while T2's relay is activated, this will have no effect
- ❑ If S2 is pushed while T1's relay is activated, this also will have no effect.

